



CLEAN AIR
FOR INDUSTRY.



OIL MIST SEPARATOR OENA-DM



THE TASK

Our OENA-DM series oil mist separators are used in cutting and shaping metalworking processes for scrubbing non water-soluble cutting fluid aerosols based on mineral, organic and synthetic oils. Reusable plastic mesh filter elements and fine-fiber material provide high-efficiency filtration of cooling lubricant aerosols. Our product lineup includes a graduated series of systems with air volumes up to 20,000 m³/h, which can be customized to even larger airflows due to their modular design.

THE SEPARATION PRINCIPLE

- Multiple stage separation process
- Reusable plastic mesh filter elements and fine-fiber material
- Separation is achieved by a combination of inertia, screening effect, coalescence and diffusion

APPLICATIONS

- Cutting processes such as drilling, turning, milling, broaching, honing, grinding
- Shaping processes such as rolling, deep drawing, pressing
- Machine tools, machining centers and transfer systems for cutting processes
- Rolling mills for sheet metal and steel, light alloys and heavy non-ferrous metals
- Presses for molding and deep drawing parts made of steel, light alloys or non-ferrous metals

HOW IT WORKS

The untreated/contaminated air enters the air inlet chamber (1) where gravitational separation removes large droplets from the air. The incoming air flow is captured in filter stage 1 (4) and is directed on to the second filtration stage (5). Both filters are reusable.

The separator is preconfigured for optional automatic rinsing, which can be activated to prevent excessive contamination of the filter media. Oil is added via an electro-pneumatic ball valve during, before or after operation of the oil mist separator. Spray nozzles (6) spray the oil on the first filtration stage (4) to flush away dirt. The separated oil mists and the rinsing agent run through the first filtration stage (4) onto the slanted floor basin (7) and exit the unit through the drain (3) with integrated siphon.

Depending on the operating conditions, the separated oil can be either reused in the machine or be pumped into a reconditioning unit. The filtration stages can be easily checked by opening the access doors. Filter elements can be removed for cleaning or exchange if necessary.

A top-mounted radial fan (8) or an external fan provides the necessary air flow and pressure differential.

After passing through the filtration stages, the cleaned air exits the unit via the fan or clean air outlet and can then be recirculated into the workplace or ducted to the outdoors, depending on workplace conditions and clean air regulations (Recirculation or vented air operation).

Depending on applicable noise regulations, installation of an exhaust silencer at the fan outlet might be required.

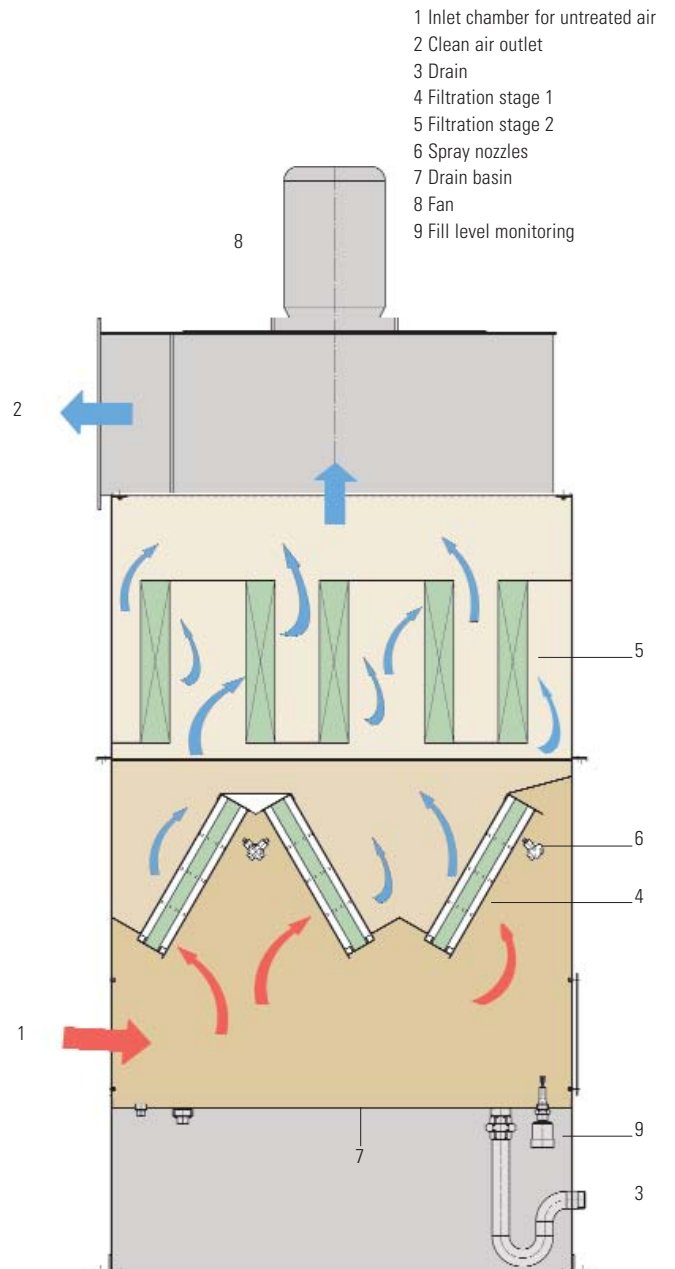

FILTER ELEMENTS

Reusable plastic mesh filter elements and fine-fiber material.

AUTOMATIC CLEANING OF FILTER ELEMENTS

The separators are preconfigured for optional automatic rinsing. The cleaning process can be configured individually to fit the specific application. It can be activated with a solenoid valve during operation (short intervals) and after the filter unit has been turned off. Oil serves as the cleaning fluid which nozzles spray onto the surface of the filter elements.

The backwashing process can also be controlled manually in "Manual Operation" mode.

DISPOSAL

The separated oil is collected in the floor basin of the unit and is then reintroduced into the oil supply cycle of the machine via a return pipe, or removed for reconditioning. The return pipe must be vacuum sealed either by using a siphon or by immersing it in the coolant sump by at least 300 millimeters.

FAN UNIT

Depending on the placement of the unit, the air volume and the required pressure differential, every configuration of the oil mist separator is available either with an external fan or with a top-mounted fan for compact overall dimensions.

RECIRCULATION OF EXHAUST AIR

The highly efficient separation of aerosols frequently allows the cleaned air to be re-circulated into the workplace. Higher concentrations of gaseous components present in the cleaned air must be ducted outdoors. As an alternative, an additional cleaning stage (cooling and condensation, or adsorption filter) is possible.

PLACEMENT

The units are designed for indoor installation. Placing the units outdoors is possible if taking special precautionary measures.

ELECTRICAL SYSTEM

The electrical controls of the system meet both VDE and our own demanding Keller standards. We will also build to customer specifications.

ACCESSORIES

- Preliminary chip separator
- Tramp oil separator
- Electro-pneumatic ball valve
- Fill level indicator
- Floor basin made from stainless steel (1.4571)
- Leakage sensor
- Tank with pump for separated cooling lubricants



UNIT DIMENSIONS AND TECHNICAL SPECIFICATIONS OENA-DMV

Please refer to illustrations below for details.

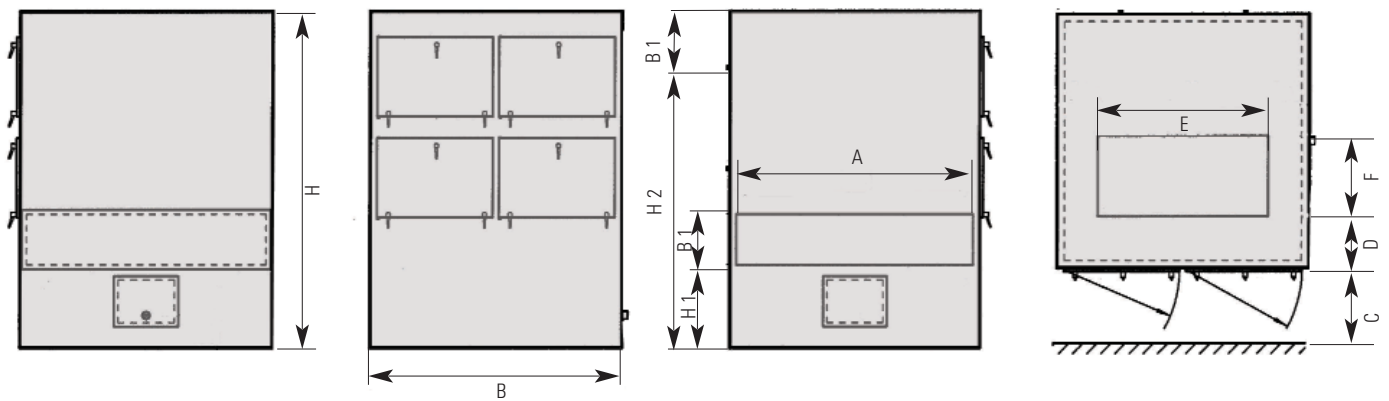

	OENA-1-DM	OENA-2-DM	OENA-3-DM	OENA-4-DM	OENA-5-DM
B	1000 x 1200	1200 x 1200	1600 x 1600	2000 x 2000	2400 x 2400
H	1750	2650	2750	2650	2650
H1	650	650	650	650	650
H2	1535	2280	2280	-	-
A	1100	1100	1500	1900	2300
B1	125	250	350	400	450
C	1300	1300	900	1300	1300
D	-	-	-	400	450
E	-	-	-	1360	1600
F	-	-	-	640	640
Untreated Air Inlet	left/right	left/right	left/right	left/right	left/right
Clean Air Outlet	left/right	left/right	left	top*	top
Rated Air Volume m ³ /h	3500	5000	10000	15000	20000
Spray Nozzles	1x	2x	6x	8x	8x
Weight in kg	410	650	1100	1800	2200

Subject to modification
 *) left/right also possible
 then A=1300, B1=250, H2=2330

UNIT DIMENSIONS AND TECHNICAL SPECIFICATIONS, OENA-DMV

Please refer to illustrations below for details.

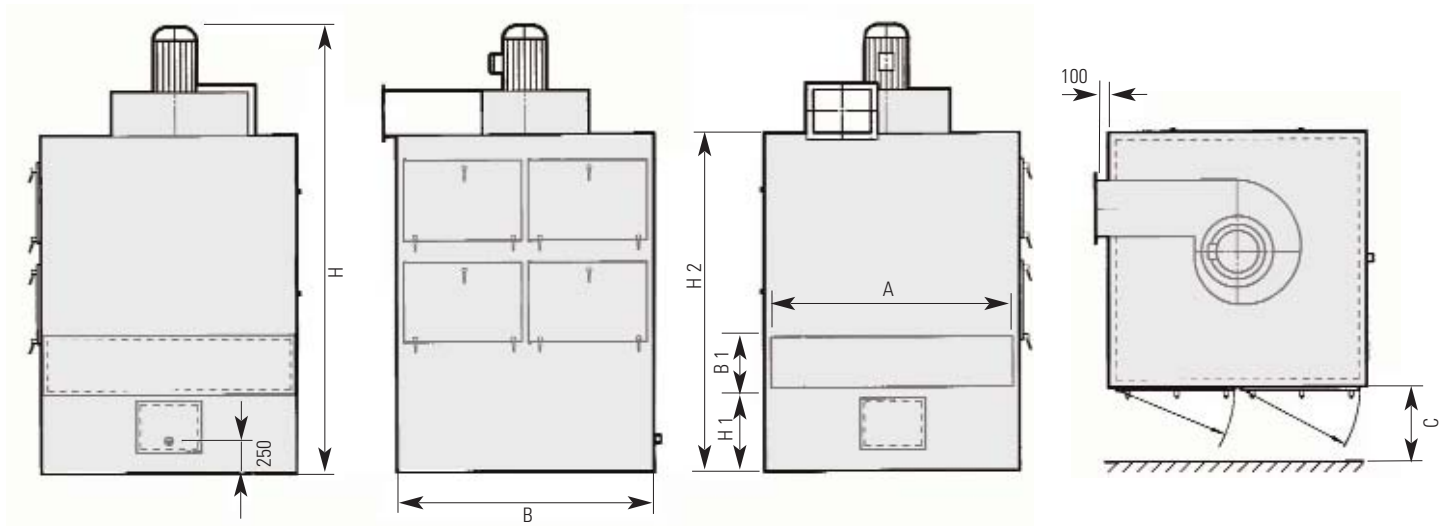

	OENA-1-DM-2.5/3.5V	OENA-2-DM-5.0V	OENA-3-DM-10V	OENA-4-DM-15V	OENA-5-DM-20V
B	1000 x 1200	1200 x 1200	1600 x 1600	2000 x 2000	2400 x 2400
H (overall with optional silencer)	2300	3270	3550	3500	3740
H1	650	650	650	650	650
H2	1700	2600	2700	2650	2650
A	1100	1100	1500	1900	2300
B1	125	250	350	400	450
C	1300	1300	900	1300	1300
Untreated Air Inlet	left/right	left/right	left/right	left/right	left/right
Clean Air Outlet	0°/90°/180°/270°	0°/90°/180°/270°	0°/90°/180°/270°	0°/90°/180°/270°	0°/90°/180°/270°
Engine Power Output kW	4	5,5	11	18,5	30
Sound Pressure Level dB (A)*	75	75	77	79	79
Air Volume rated at m ³ /h	2500/3500	5000	10000	15000	20000
Spray Nozzles	1x	2x	6x	8x	8x
Weight in kg	570	820	1310	2180	2850

Subject to modification
*) measured at a distance of 1 m from the unit (door),
measured according to DIN EN ISO 3744

COMPACT SEPARATION TECHNOLOGY – OIL MIST SEPARATOR OENA-K

HIGHLY EFFICIENT SEPARATION FOR METALWORKING APPLICATIONS

With the oil mist separators of the OENA-K series, Keller Lufttechnik has developed a compact unit for capturing and separating cooling lubricant aerosols created by mineral, organic, and synthetic oils. This unit can be used as an independent unit or situated on top of or adjacent to a machine tool.

The control of the separator can be effected directly via the machine. As an alternative, we have a range of controls available. They can either be attached to the system or delivered separately. For this purpose we dispose of plug-type connections in different lengths.

SEPARATION PRINCIPLE

A multi-stage separation process cleans the untreated air using a combination of inertia, screening effect, coalescence and diffusion. The composition of the reusable wire mesh filter elements and fine-fiber material is customized to separate the specific droplet spectrum of the application. As an option, a third filtration stage (for the separation of fumes and smoke) can be added.

ACCESSORIES

- Downstream Filter
- Spraying of filtration stage 1



APPLICATIONS

- Cutting processes such as drilling, turning, milling, broaching, honing, grinding
- Shaping processes such as rolling, deep drawing, pressing
- Machine tools, machining centers and transfer systems for cutting processes
- Rolling mills for sheet metal and steel, light-alloy and non-ferrous metal profiles
- Presses for molding and deep-drawn parts made from steel, light-alloy or non-ferrous metals
- Die casting machines
- Grinding machines

ADVANTAGES

- Small and compact filter housing
- Machine top mounting possible
- Switch and control system loosely or attached
- Turnable by 180°
- 24-hour operation with option to rinse during operation
- No downtime required

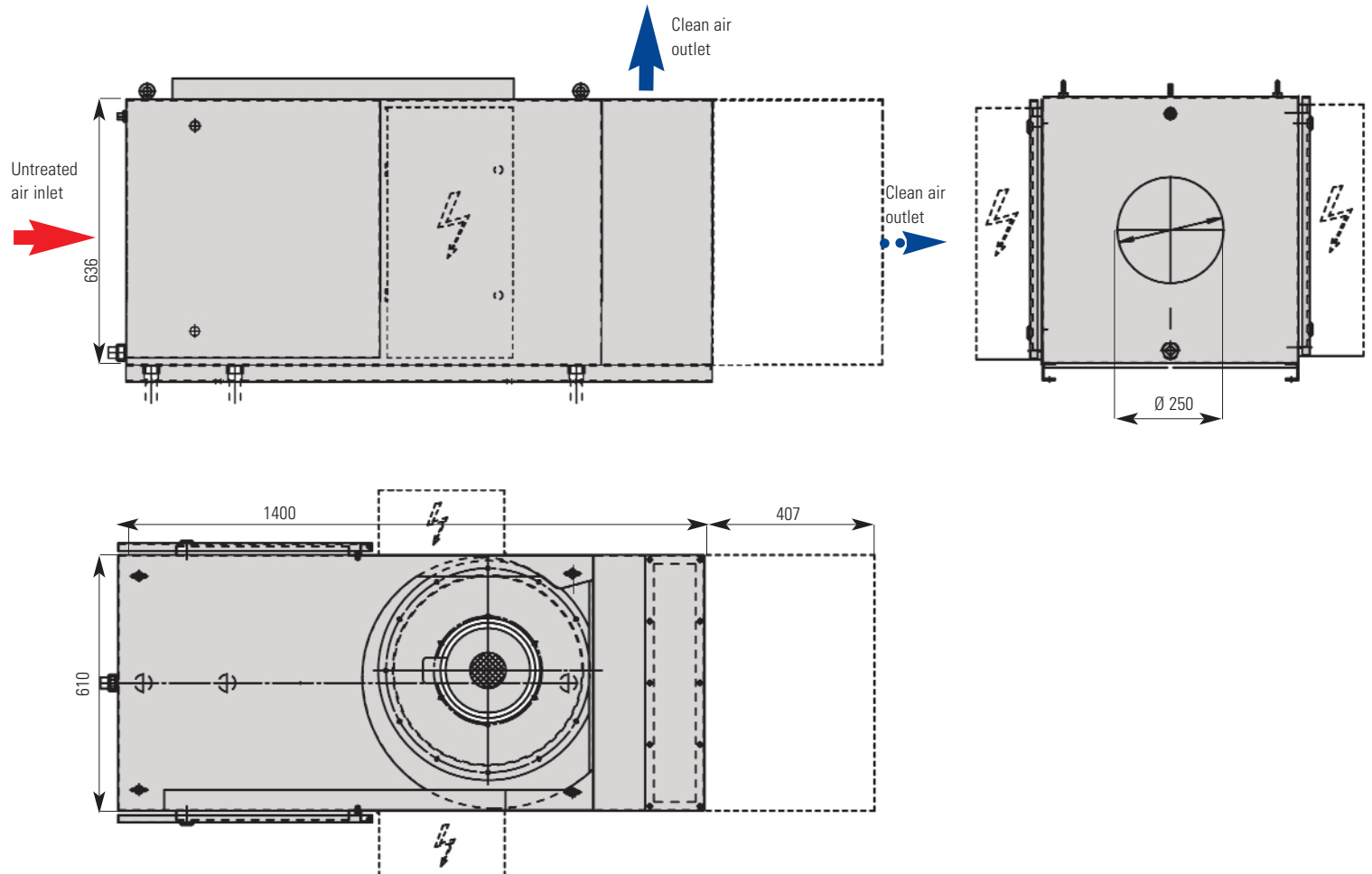

OENA-K	OENA-1-K-1.0	OENA-1-K-2.0	OENA-1-K-2.0
NW untreated air inlet	Ø 250	Ø 250	Ø 250
Optional 3. Filter Stage B1 [mm]	407	407	407
Untreated Air Inlet	left/right	left/right	left/right
Clean Air Outlet	right/left	right/left	right/left
Engine Power Output kW	1,5	3,3	3,3
Sound Pressure Level dB (A)*	72	72	72
Air Volume rated at m ³ /h	1000	1500	1000**
Spray Nozzles	1x	1x	1x
Weight in kg	ca. 175	ca. 175	ca. 175

Subject to modification

* measured at a distance of 1 m from the unit (door),
measured according to DIN EN ISO 3744

** Separator for finer aerosol mist
with increased filtration stage 2



REFERENCES END COSTUMERS

ACI, France
AUDI, Germany, Hungary
BMW, Germany, Great Britain, Austria
BOSCH, Stuttgart
CONTINENTAL TEVES, Gifhorn
DAIMLER, Germany, Mexico
DEUTZ, Köln
FEDERAL MOGUL, Germany
FORD, England, Germany, Brasilia, Spain, Mexico
GETRAG, Germany, England, Slovakia, France
GM, Germany
HÄRING, Bubsheim
MTU, Friedrichshafen, Munich
OPEL, Germany, Austria, Hungary
PEUGEOT, France
PORSCHE, Germany
SEAT, Spain
VW, Germany, Mexico, China, Belgium
VISTEON, Germany
DODGE EUROPE ELZTAL, Dallau
EKERT HERMANN GMBH, Sulzbach
HEIDELBERGER DRUCKMASCHINEN, Wiesloch
HEYLIGENSTAEDT, Giessen
HFP BANDSTAHL, Salzingen
HIRSCHVOGEL KOMPONENTEN, Schongau
PELTEP, Poland



REFERENCES MACHINE MANUFACTURERS

GROB, Mindelheim
CHIRON, Tuttlingen
DMG, Burscheid
INDEX, Esslingen
MAG POWERTRAIN, Eislingen
TRAUB, Plochingen
EMAG Maschinen, Salach
EMAG Leipzig GmbH, Leipzig
WEISSER, St. Georgen



Keller USA, Inc.
54 Great Hill Road, P.O. Box 546
Naugatuck, CT 06770 USA
Phone (203) 729-0145 . Fax (203) 729-0148
E-mail: info@kellerusa.com
www.kellerusa.com